

# RING PACKER ROLLER - FOLDING CARTED



## 6.7M FOLDING CARTED PACKER ROLLER

Proudly Australian Made

The DELMADE Packer Roller is designed to preserve soil moisture and improve seed bed preparation. Used behind an Offset Disc or similar cultivation machine, it seals the top few inches of worked soil whilst breaking down large clods to leave a level finish & make the second pass more comfortable.

The pressing action delivers optimum seed to soil contact, even in the presence of trash and stubble, helping improve germination and moisture retention. In addition the soil is levelled and conditioned so it is friable and receptive to further rainfall, whilst the characteristic herringbone pattern also assists in controlling wind and water erosion. After harvesting, this implement is also effective in stubble management or knockdown, allowing faster break down of stubble residue.

## FEATURES & BENEFITS

- Cast Rings in V formation
- 2" Axle & 2" Sealed Bearings
- Centre Bearing
- Preserves soil moisture
- Breaks down large clods
- Herringbone Pattern assists in wind & water erosion issues.
- Adjustable drawbar, ability to track to left or right
- Levels and conditioned soil so it is friable and receptive to further rainfall

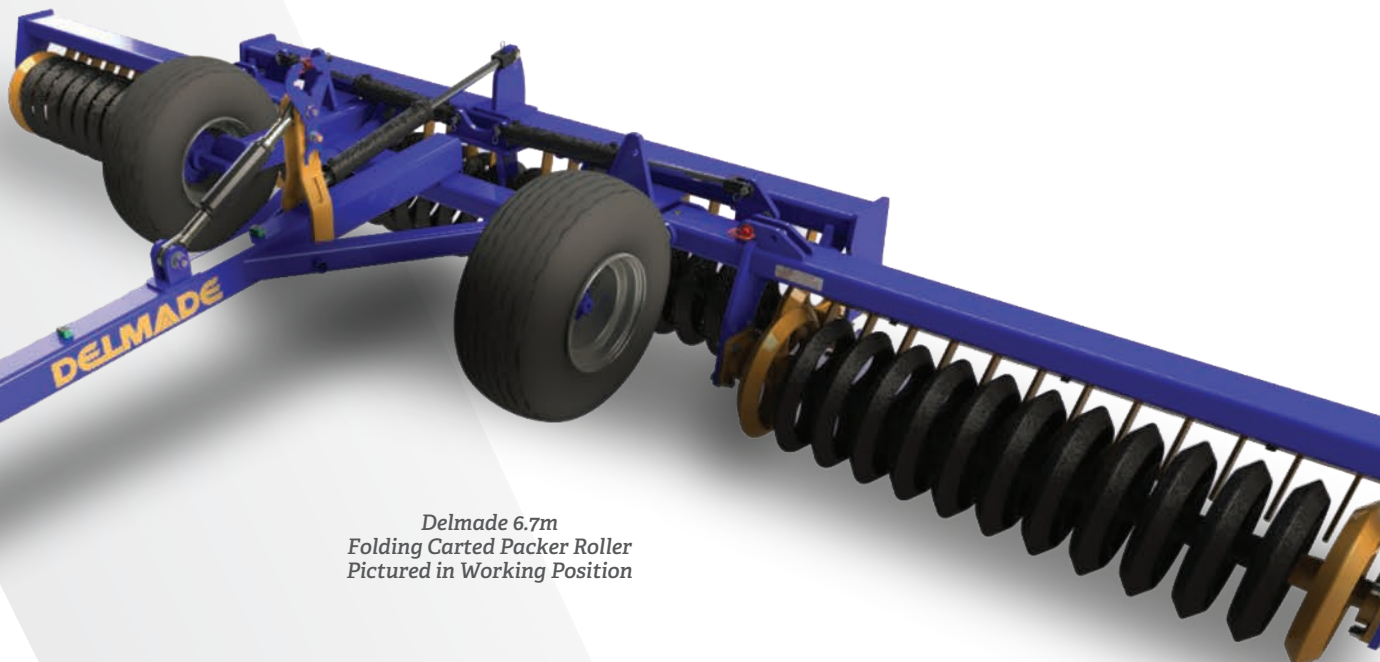

*Delmade 6.7m  
Folding Carted Packer Roller  
Pictured in Working Position*



Delmade Specification Cast Ring Roller Segment 19" x 2-1/2"

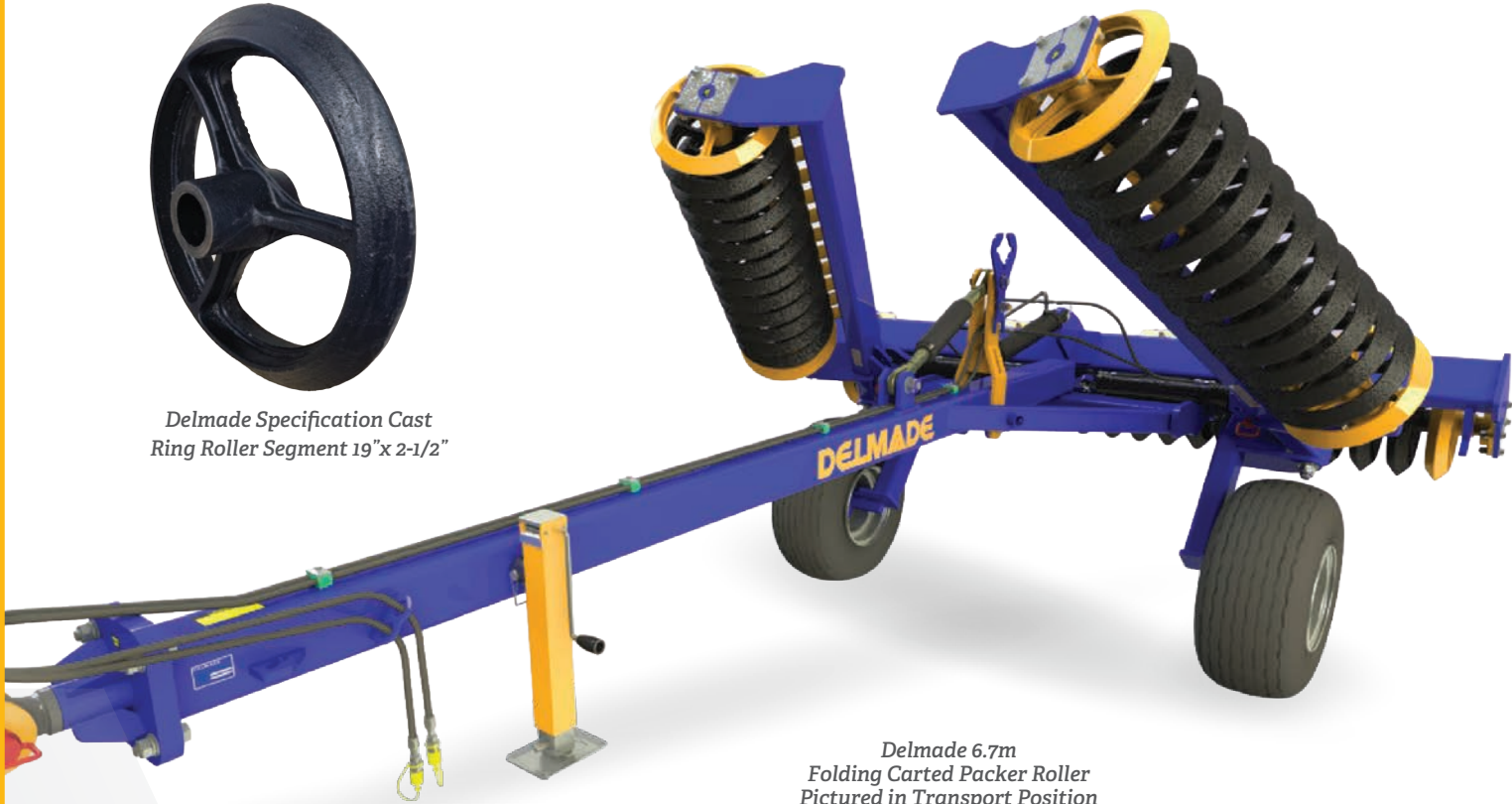

Delmade 6.7m Folding Carted Packer Roller Pictured in Transport Position

The folding DELMADE Packer Roller is engineered to deliver the same proven seed bed performance while offering improved transport safety and paddock efficiency. The folding design allows for a reduced transport width, making road travel safer and easier while minimising downtime between paddocks.

Once unfolded, the machine provides excellent ground coverage, allowing larger areas to be completed efficiently without compromising finish quality.

## FOLDING CARTED MODEL

- Hydraulic folding design for reduced transport width
- Safer and easier road transport
- Increased working width for improved efficiency

## SPECIFICATIONS

PRODUCT CODE	WORKING WIDTH		POWER REQUIREMENT		TRANSPORT WIDTH		TOTAL WEIGHT (KG)
	METRIC (M)	IMPERIAL	KW	HP	METRIC (M)	IMPERIAL	
DRO0250	4.8	15'8"	36+	48+	3.39	11'1"	2750
DRO0255	5.3	17'6"	40+	53+	3.39	11'1"	2840
DRO0260	5.6	18'5"	42+	56+	3.39	11'1"	3020
DRO0265	6.2	20'3"	46+	62+	3.39	11'1"	3200
DRO0270	6.7	22'1"	50+	67+	3.39	11'1"	3370
DRO0275	7.3	23'11"	55+	74+	3.39	11'1"	3550
DRO0280	7.9	25'9"	60+	81+	4.23	13'11"	3730
DRO0285	8.4	27'7"	65+	87+	4.23	13'11"	3910
DRO0290	8.7	28'7"	69+	92+	4.23	13'11"	3990

YOUR LOCAL STOCKIST:

**DELMADE**  
Shaping the Land

1800 335 623  
info@delmade.com.au  
www.delmade.com.au